

TSZC-06 Zoom Lens Controller

User's Manual

2019. 6 1st Edition

Contents

Introduction	4
Introduction · Connection	8
Driver · Software	10
Specification · Control Commands	14

Introduction

Read this user's manual before use.

After you read this manual, keep it in a safe place for future reference.

■ Symbols

In this manual, the following symbols alert you to important messages.

Be sure to read the messages.



DANGER

It indicates a hazardous situation which, if not avoided, will result in death or serious injury.



WARNING

It indicates a hazardous situation which, if not avoided, could result in death or serious injury.



CAUTION

It indicates a hazardous situation which, if not avoided, could result in minor or moderate injury.

Important

It indicates cautions and limitations that must be followed during operation.

Point

It indicates additional information on proper operation.

The company names and product names used in this manual are registered trademarks or the trademarks of their respective companies.

Safety Information



CAUTION

■ General Precautions

- At startup and during operation, be sure to monitor the functions and performance of the TSZC Series.
- We recommend that you take substantial safety measures to avoid any damage in the event of a problem occurring.
- Do not attempt to open or modify the TSZC Series or use it in any way other than as described in the specifications. If the TSZC Series is modified or used other than as described, the warranty will be voided.
- Do not allow the temperature to change sharply around the TSZC Series, including the accessories. Otherwise, condensation may lead to malfunction.



WARNING

■ Precautions for use

- Do not use the TSZC-06 at a voltage other than 100 V AC. Failure to do so may cause fire, electric shock, or a product damage.
- Do not disassemble or modify this instrument. Doing so may cause fire and electric shock.

■ Precautions in Emergency

- Turn the power off immediately in the following cases.
Using the unit in an abnormal condition could cause fire, electric shock, or accident.
Contact the Seller office for repair.
- If liquid, including water or chemicals, or debris enters the unit.
- If the unit is dropped or the case is damaged.
- If abnormal smoke or odor is present.



■ Precautions on installation

- To use this instrument correctly and safely, avoid installing it in the following locations. Installation in such locations may cause malfunction.
- Locations that are humid, dusty or poorly ventilated.
- Locations where the temperature is high such as those exposed to direct sunlight.
- Locations where there are flammable or corrosive gases.
- Locations where the unit may be subject to vibration or impact.
- Locations where water, oil, or chemicals may splash onto the instrument.
- Locations that are prone to static electricity

■ electrical noise

- Installing the instrument in the vicinity of an electrical noise source such as a power source and high-voltage line could cause malfunction and instrument damage due to noise. Take preventive actions such as using noise filters, separating cables.

Use single-conductor shielded cable for the analog output cable.

NOTE

■ Precautions in storing

Do not wipe the instrument with a wet wipe, benzene, or thinner. Doing so could change the color or shape of the instrument.

If the instrument has a large amount of dirt on it, wipe it off with a cloth moistened with a mild detergent, then wipe with a soft dry cloth.

Introduction

The TSZC Series Controller is designed to control the position of the zoom lens.

The controller stores values of the potentiometer inside the zoom lens and divides the movement range into 1,000 positions*2 to control the position.

For communication, USB or RS-232C serial communication*3 is used. By sending simple commands from a PC or other equipment, users can use this controller to quickly move the zoom lens to a specified position.

Part Names and Connections

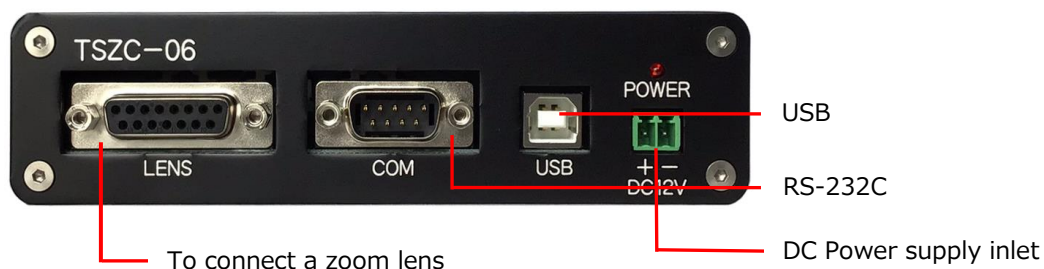

Note: The unit shown in this photo is a development unit.
The actual product has a port for either USB or RS-232C.

Zoom Lens Connector : DSub15pin

D-Sub Connector is included.

USB : Connects to a P.C. With a USB cable. (Type B)

DC Power supply inlet : Connects to a DC power cable.



CAUTION

Do not connect the DC power supply
Other than the supplied with this product.

Wiring diagram

The wiring diagram of the Zoom lens. (D-Sub 15pin)

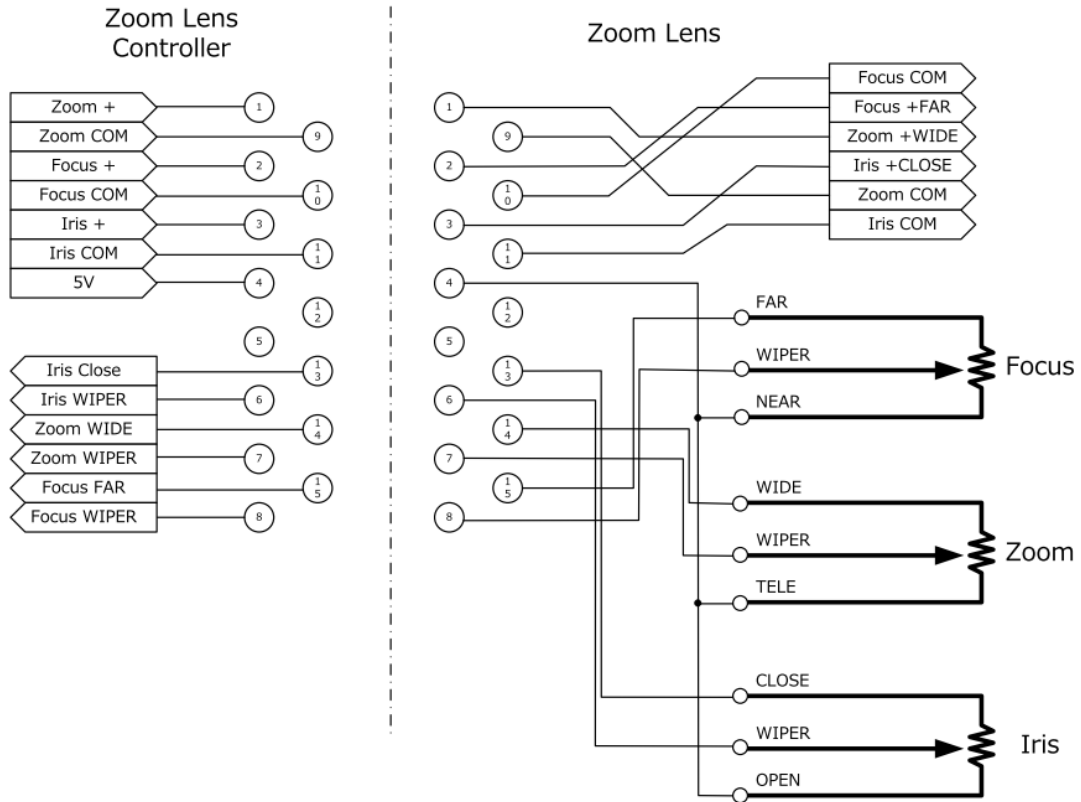

Please wire it in reference to this drawing.

Driver · Software

※ When using on Windows 10

It can operate with the USB serial driver acquired from windows update.

※ When using with special equipment configuration

USB-type C devices such as Apple's MacBookPro via USB-HUB

When you use it, there are rare cases that you do not recognize.

In this case, it will work if you connect via USB 2.0 HUB.

Driver installation.

This Zoom Lens Controller uses a FTDI USB virtual COM driver.

Also,

<http://www.ftdichip.com/Drivers/VCP.htm>

So is provided as the right OS FTDI driver,

Please check there too.

Installation is after running

“CDM v2.08.30 WHQL Certified.exe”

Follow the instructions in the installer.

Installation work, please run the

“CDM v2.08.30 WHQL Certified.exe” installer.

Steps should follow the instructions on the screen of the installer.

Control Software

Download the software from the TSZC-06 product page.

product page URL : <http://tesbit.co.jp/?p=1155>

The software includes "Software" folder in the CD-ROM.

"x64" folder: 64-bit software for Windows

"x86" folder: 32-bit software for Windows

Use the copy to any folder.

Includes software as source code created in VB.net(VB2010).

To assist in development.

Screen description

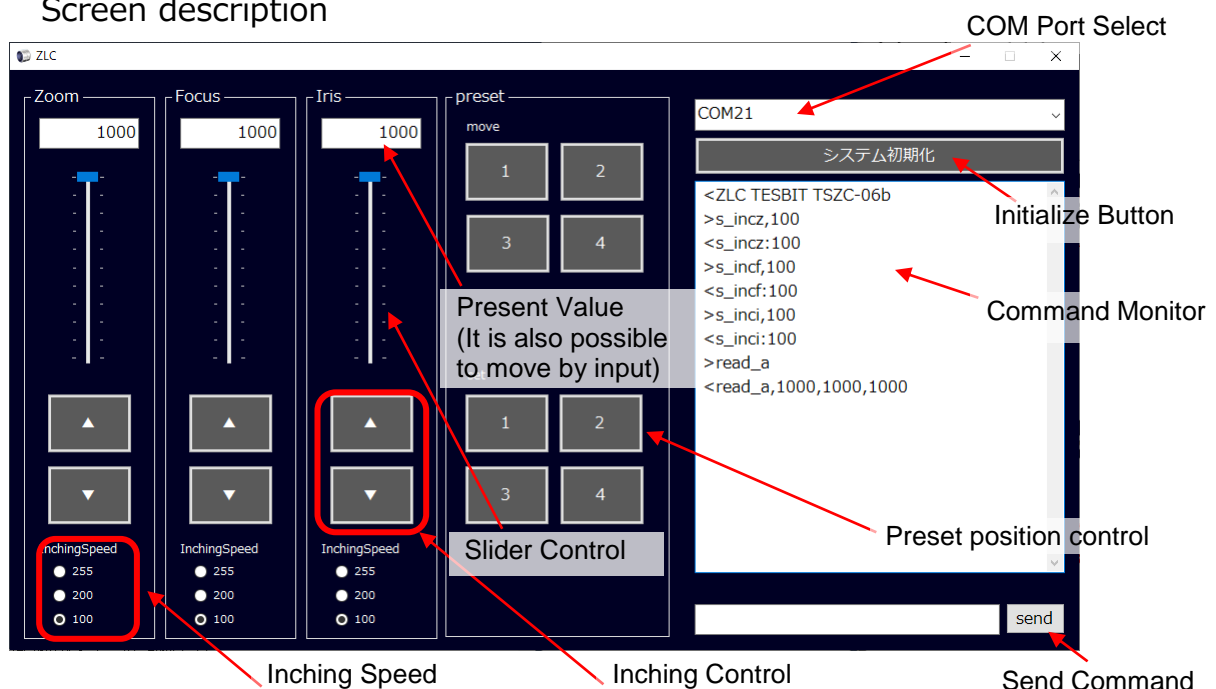

Execute "Initialize" at the first startup.

Register the potentiometer value of the zoom lens.

Operation

Introduction

Before using this software, Please install a driver software in a P.C.
Please state the PC recognize the Zoom Lens Controller.

1. Initialize

To run the software for the first time this warning will be shown.

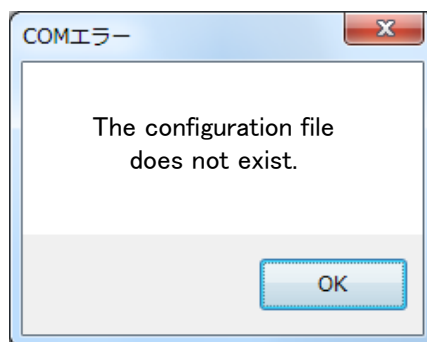

Click the [OK] button.

2. Set the COM Port for the RS-232c communication.

3. Press the [initialize] button, the recorded value of the potentiometer.

It is work to initialize the Zoom Lens Controller work up here.

Once the initialization is done, up to section 3 is not required.

4. Press the button you want to operate and run the lens.

Serial Communication (RS-232c) Control (OPTION)

Serial communication specifications

EAI RS-232c compliant

Baud rate	9600,14400,19200,28800,38400
Data length	8bit
Parity	None
Stop length	1bit
Flow control	None
Data Delimiter	CR

※The command is the same as USB communication.

※Data Delimiter is different : CR (USB : CRLF)

※Connection using cross-over cable.

※Baud rate : Default 38400

Abnormality detected (forcibly allocated) 9600

Specification · Control Commands

Specification

Name	Zoom Lens Controller
Type	TSZC-06
Compatible Zoom Lens	DC12V Power zoom lenses Made by SPACE, Inc.
Control	Zoom/Focus/Iris
Communication System	USB2.0 (USB-Serial Communication) Option:RS-232c
Baud rate	9600,14400,19200,28800, 38400(Default)
Data length	8 bit
Parity	None
Stop length	1 bit
Flow control	None
Data Delimiter	CR, LF, CRLF
Control Capability	Resolution:1000step Movement Speed: changes with zoom lenses.
Applied Voltage on Zoom lens	12V DC
Main Power Supply	12V DC
Standard Dimensions	142 x 36 x 96[mm] (excluding protrusions)

※Baud rate : Default 38400

Abnormality detected (forcibly allocated) 9600

Unless an incorrect value is set at the time of setting, the baud rate is fixed.

2019.6 Zoom Lens Controller ZLC series
Command List 1/2

Item	CMD No.	workings	Explain	Argument	sample	Return value	Note
Initialize	1	init_a Initialize	Controller-initialization functions. Each lens of movement and the Get the potentiometer min max.	none	init_a	init_a_j; init_a_z; init_a_f; Progress is reported. init_a_done; and the end.	
	2	init_z Zoom Initialize	Zoom Initialization	none	init_z	init_z;	
	3	init_f Focus Initialize	Focus Initialization	none	init_f	init_f;	
	4	init_l Iris Initialize	Iris Initialization	none	init_l	init_l;	
Settings	5	movesp Max Speed	Set the move at maximum speed Setting range: 1 ~ 255	move speed	movesp,180	movesp,setting value	※Note Change of set value range
	6	inchsp Inching Speed	Set of inching operation, adjusting speed Setting range: 1 ~ 255	inching speed z,f,c	inchsp,150,150,150	inchsp z:setting value f:setting value	※Note Change of set value range
	7	s_inca Inching Speed	Set of inching operation, adjusting speed Setting range: 1 ~ 255	inching speed z,f,c	inca,150,150,150	s_inca z:setting value f:setting value	※Note Change of set value range
	8	s_incz Zoom Inching Speed	Set zoom inching speed	inching speed	s_incz,150	s_incz,setting value	
	9	s_incf Focus Inching Speed	Set focus inching speed	inching speed	s_incf,200	s_incf,setting value	
	10	s_incl Iris Inching Speed	Set iris inching speed	inching speed	s_incl,150	s_incl,setting value	
	11	l_tout Initialization Timeouts	Set the initialization time-out time Setting range: 100 ~ 20000 [ms]	timeouts	l_tout,10000	l_tout,setting value	
	12	m_tout Move Timeouts	Set the movement time-out time Setting range: 100 ~ 20000 [ms]	timeouts	m_tout,10000	m_tout,setting value	
	13	mv_thd Movement range threshold ※Notice	Target value during movement ± range threshold Setting range: 0~10 (it takes time if 0)	Threshold	mv_thd,0	mv_thd,setting value	After moving by mechanical inertia etc.,it may not fit within the threshold range.
	14	mv_wat Movement standby time	When moving, Standby time at the transition from coarse adjustment to fine adjustment operation. Setting range: 0~1000[ms]	Waiting time	mv_wat,100	mv_wat,setting value	To avoid inertia during rough adjustment it is the standby time
	15	fcinit Flying movement	In the slow lens operation to flying movement. Setting range: 0 ~ 20000 [ms]	flying time	fcinit,200	fcinit,setting value	
	16	s_echo Communication echo back availability	Set of echo back availability	0: None 1: Present	s_echo,0	s_echo = off	
17	s_baud Communication baud rate setting	Set of communication speed (with designated speed))	Baud rate	s_baud,38400	Message prompting to restart the host	Selection of 9600, 14400, 19200, 28800, 38400 Initial value is forced to 9600 when 38400 error	
18	s_oldc Old Type communication setting	Communication method of old TSZC series availability	0: New model 1: Old model	s_oldc,0	s_oldc = off	Older style communicates without using send command line feed code.	
19	s_inlcd Line feed code	Set the line feed code at communication	0=CR+LF / LF 1=CR				
20	s_prst Preset value	Set the preset value	preset number (1~4) ,z,f,i	pres, preset number,z,f,i			

※ Notice

Items 14, 15, 17, 18, 19 can be used from the shipment after May 2016.

There is a reply when setting an incorrect value by the setting command. In the case of
However, since the baud rate (s_baud) is an important setting, it is forcibly set to 9600 bps.

mv_thd is a command to set tolerance (threshold) to the target value when moving the move command.
For example, when moving to the position of 200, if the mv_thd value is 1, the machine will position within the range of 199 to 201.
However, depending on the lens inertia, this is not the limit. (Please refer to the notes on the next page)

2019.6 Zoom Lens Controller ZLC series
Command List 2 / 2

Item	CMD No.	workings	Explain	Argument	sample	Return value	Note		
MOVE	21	move.a move	To move Zoom, focus, Iris	z,f,I	move_a,800,500,500	Reply the move_I; move_f; move_z;	Move the actual works in order of I, f, z		
	22	move.z move	To move Zoom.	z	move_z,400	move_z;			
	23	move.f move	To Move Focus	f	move_f,500	move_f;			
	24	move.i move	To Move Iris.	I	move_I,600	move_I;			
	25	move.p move (Preset)	To move Zoom, focus, Iris	preset number	move_p,1	Reply the move_I; move_f; move_z; move_a/move_p_done;	Move the actual works in order of I, f, z		
	26	inc.zf inching	Zoom move in the +direction	none	inc.zf	none			
	27	inc.zr inching	Zoom move in the -direction	none	inc.zr	none			
	28	inc.ff inching	Focus move in the +direction	none	inc.ff	none			
	29	inc.fr inching	Focus move in the -direction	none	inc.fr	none			
	30	inc.if inching	Iris move in the +direction	none	inc.if	none			
	31	inc.ir inching	Iris move in the -direction	none	inc.ir	none			
	32	instop stop inching	Stopping the inching	none	instop	instop;			
	Position	33	read.z position read	Get the value of Zoom	none	read_z,ZZZ	read_z,ZZZ	zzz:zoom value	
		34	read.f position read	Get the value of Focus	none	read_f,FFF	read_f,FFF	FFF:Focus value	
		35	read.I position read	Get the value of Iris	none	read_I,III	read_I,III	III:Iris value	
		36	read.a position read	Get the value of all position	none	read_a	read_a,ZZZ,FFF,III		
		37	readsa position read	Get the value of all position(pure A/D value)	none	readsa	readsa,ZZZ,FFF,III		
		38	readsz position read	Get the value of Zoom position(pure A/D value)	none	readsz	readsz,ZZZ		
		39	readsf position read	Get the value of Focus position(pure A/D value)	none	readsf	readsf,FFF		
		40	readsi position read	Get the value of Iris position(pure A/D value)	none	readsi	readsi,III		
		Other	41	memchk memory check	Gets the value of the Flash memory	none	memchk	Flash memory data	
			42	read.p preset memory check	Gets the value of the preset memory	preset number	read_p,1	preset_preset number:ZZZ,FFF,III	
	43		firmver Firm Ver. check	Firmware version check	none	firmver	version information		

※NOTE

If you send the command, do not Data Delimiter. (Please do not use in case of old TSZC - 04 (before May 2016))

When installing the Zoom Lens, the initialization(init_a) should do.

If you do not operate the inching, increase the speed.

※Important notes

When the zoom lens is driven, it slightly coasts due to the inertia of the lens. This tends to be larger when the lens is mounted vertically.

Therefore, when moving to the target value with the move command, deviation of about ± 2 may occur.

Even if the threshold value for the target value is set to 0 with the mv_thd command, it may be shifted up to ± 2 at the maximum.

(Horizontal displacement will decrease)